

HELIX[®] GRINDER OPERATING & SERVICE MANUAL



Read Manual Before Operating or
Servicing Machine

403223 Rev H

Table of Contents

Table of Contents	3
Features and Specifications	4
Safety	6
General Rules for Safe Operation	6
Grinder Safety Guidelines.....	7
Electrical Practices	8
Components and Assembly	10
Loading and Unloading.....	10
Disassembling and Assembling Machine	10
Dual Speed	11
Vacuum Port	11
Tooling Setup	11
Edge Grinding.....	13
Operation	14
Pre-Operation Safety Checks	14
Operating Controls.....	14
Operating Procedure	14
Down Pressure	15
Adjusting the Cam Levers/Handle	15
Adjusting the Light	15
Troubleshooting Guide	17
Maintenance	18
General Maintenance	18
Removing Tooling Assembly.....	18
Replacing Nylon Clutch	18
Replacing Satellite Bearing Assemblies	19
Replacing Morflex Couplers.....	19
Replacing Motor Brushes	20
Light	21
Accessing Electrical Components	21
Parts List and Diagrams	22
Overall Machine.....	22
Base Assembly	23
402757 Tooling Assembly	24
403231 Skirt Assembly	25
Motor.....	26
Lower Handle Assembly	27
Upper Handle Assembly	28
Handle Assembly (International Only)	29
Control Panel	30
Labels	32
Wiring Diagrams	33

Features and Specifications



FEATURES

Floating Tooling Assembly- Allows the cutting head to follow the contour of the surface, providing uniform operation in low spots.

16" Tooling Assembly - Creates a 16" wide cutting path. Rotates 180° for easy tooling changes.

1.5 HP Motor - Draws less than 15 amps at full load.

Edge Grinding - Operates within 1/8" of the wall using either side of the machine.

Dual Speed - Allows the tooling assembly to spin at different speeds.

Floating Dust Skirt - Allows the dust skirt to follow the contour of the surface, providing a virtually dustless operation

Removable Tooling Assembly - Allows for easy access and mobility.

Adjustable Handle - Accommodates wide range of operator heights.

Collapsible Handle Assembly - Allows the handle to collapse to 2/3 of its size for easy handling and transportation.

Features and Specifications

Product Specifications

Width	Length	Height	Weight	HP	Disk Size
Max: 17.5" (44.5 cm) Min: 16.9" (42.9 cm)	Max: 47" (119.4 cm) Min: 27.9" (70.9 cm)	Max: 47.6" (120.9 cm) Min: 29.4" (74.7 cm)	206 lbs (93.4 kg) with tooling assembly 180 lbs (81.6 kg) without tooling assembly	1.5	16" (40.6 cm)

Machine Variants

Region	Serial Number	Input Power	Amps (Full Load)	Motor RPM (High/Low Speed)	Tooling Assembly RPM (High/Low Speed)
Domestic (North America)	HELIX-10XXXX	120V / 60 Hz	15A	3339 / 1878	304 / 171
	HELIX-12XXXX	120V / 60 Hz	15A	3339 / 1878	304 / 171
	HELIX-23XXXX	120V / 60 Hz	15A	3339 / 1878	304 / 171
International	HELIX-11XXXX	230V / 50 Hz	8A	3200 / 1800	291 / 164
	HELIX-13XXXX	230V / 50 Hz	8A	3200 / 1800	291 / 164
	HELIX-15XXXX	230V / 50 Hz	8A	3200 / 1800	291 / 164
	HELIX-20XXXX	110V / 50 Hz	15A	3061 / 1722	278 / 157
	HELIX-26XXXX	230V / 50 Hz	8A	3200 / 1800	291 / 164
	HELIX-27XXXX	230V / 50 Hz	8A	3200 / 1800	291 / 164
	HELIX-28XXXX	100V / 50/60 Hz	15A	2783	253

Safety

GENERAL RULES FOR SAFE OPERATION

Before use, anyone operating or performing maintenance on this equipment must read and understand this manual, as well as any labels packaged with or attached to the machine and its components. Read the manual carefully to learn equipment applications and limitations, as well as potential hazards associated with this type of equipment. Keep manual near machine at all times. If your manual is lost or damaged, contact National Flooring Equipment (NFE) for a replacement.

Personal

Dress properly and use safety gear.

Do not wear loose clothing; it may be caught in moving parts. Anyone in the work area must wear safety goggles or glasses and hearing protection. Wear a dust mask for dusty operations. Hard hats, face shields, safety shoes, etc. should be worn when specified or necessary.

Maintain control; stay alert.

Keep proper footing and balance, and maintain a firm grip. Observe surroundings at all times. Do not use when tired, distracted, or under the influence of drugs, alcohol, or any medication that may cause decreased control.

Keep hands away from all moving parts and tooling.

Wear gloves when changing tooling. Remove tooling when machine is not in use and/or lower cutting head to the floor.

Do not force equipment.

Equipment will perform best at the rate for which it was designed. Excessive force only causes operator fatigue, increased wear, and reduced control.

Environment

Avoid use in dangerous environments.

Do not use in rain, damp or wet locations, or in the presence of explosive atmospheres (gaseous fumes, dust, or flammable materials). Remove materials or debris that may be ignited by sparks. Keep work area tidy and well-lit - a cluttered or dark work area may lead to accidents. Extreme heat or cold may affect performance.

Protect others in the work area and be aware of surroundings.

Provide barriers or shields as needed to protect others from debris and machine operation. Children and other bystanders should be kept at a safe distance from the work area to avoid distracting the operator and/or coming into contact with the machine. Operator should be aware of who is around them and their proximity. Support personnel should never stand next to, in front of, or behind the machine while the machine is running. Operator should look behind them before backing up.

Guard against electric shock.

Ensure that machine is connected to a properly grounded outlet. Prevent bodily contact with grounded surfaces, e.g. pipes, radiators, ranges, and refrigerators. When scoring or making cuts, always check the work area for hidden wires or pipes.

Maintenance & Repairs

Begin maintenance work only when the machine is shut down, unplugged, and cooled down.

Use proper cleaning agents.

Ensure that all cleaning rags are fiber-free; do not use any aggressive cleaning products.

Schedule regular maintenance check-ups.

Ensure machine is properly cleaned and serviced. Remove all traces of oil, combustible fuel, or cleaning fluids from the machine and its connections and fittings. Retighten all loose fittings found during maintenance and repair work. Loose or damaged parts should be replaced immediately; use only NFE parts.

Do not weld or flame-cut on the machine during repairs, or make changes to machine without authorization from NFE.

Equipment

Use proper parts and accessories.

Only use NFE-approved or recommended parts and accessories. Using any that are not recommended may be hazardous.

Ensure accessories are properly installed and maintained.

Do not permanently remove a guard or other safety device when installing an accessory or attachment.

Inspect for damaged parts.

Check for misalignment, binding of moving parts, loose fasteners, improper mounting, broken parts, and any other conditions that may affect operation. If abnormal noise or vibration occurs, turn the machine off immediately. Do not use damaged equipment until repaired. Do not use if power switch does not turn machine on and off. For all repairs, insist on only identical NFE replacement parts.

Maintain equipment and labels.

Keep handles dry, clean, and free from oil and grease. Keep cutting edges sharp and clean. Follow instructions for lubricating and changing accessories. Motor and switches should be completely enclosed at all times with no exposed wiring. Inspect cord regularly. Labels carry important information; if unreadable or missing, contact NFE for a free replacement.

Avoid accidental starting; store idle equipment.

When not in use, ensure that the machine is unplugged; do not turn on before plugging in. Store in a dry, secured place. Remove tooling when storing, and keep away from children.

GRINDER SAFETY GUIDELINES

Before use, anyone operating this equipment must read and understand these safety instructions.

Grinding

Beware of hidden obtrusions.

Watch out for hidden dangers and protrusions in flooring. Do not use on largely uneven surfaces.

Avoid contact with hot tooling and shroud.

Do not touch the tooling or shroud without proper hand protection. Both become hot during operation and remain hot after stopping the machine.

Use correct tooling and accessories.

Provide barriers or shields as needed to protect others from debris.

Use for correct applications.

Do not force equipment to do heavier duty work than it was made for.

Do not block the machine's air flow.

Blocking ventilation slots or air flow will result in damage to the machine. Leave space for air to flow freely during operation.

Use safety key and wrist wrap during operation.

Loss of control of the grinder could cause damage, injury, or death.

Dust Collection

Use with appropriate dust collecting system.

Do not operate machine designed for use with a dust collector without the dust collector. Ensure dust collector is on and operating properly while grinding.

Use with appropriate dust collection hose.

Do not operate the machine without the hose securely attached to the inlet of the dust collector and the outlet of the grinder. In order to maintain system efficiency, do not use a damaged hose.

Dispose of collected waste.

Do not leave the dust collector bag full of waste. Handle and dispose of bag and waste in accordance with all applicable local, state, and federal regulations. Dispose of waste prior to transport.

Battery (Propane Machines Only)

Remove personal metal items when working with battery.

A battery can produce a short circuit current sufficient enough to weld metal objects, causing severe burns. Be careful to not drop metal tools on the battery, as a spark or short circuit could cause an explosion.

Never smoke or allow a spark or flame near the battery.



WARNING: BE CAUTIOUS WHEN WORKING WITH BATTERY. IF ELECTROLYTIC ACID GETS IN THE EYES, IMMEDIATELY FLUSH OUT WITH COLD, FRESH WATER FOR AT LEAST 10 MINUTES AND GET MEDICAL HELP.

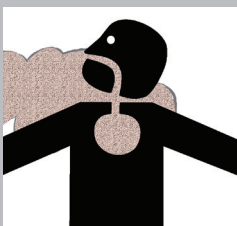

WARNING: GRINDING/CUTTING/DRILLING OF MASONRY, CONCRETE, METAL AND OTHER MATERIALS CAN GENERATE DUST, MISTS AND FUMES CONTAINING CHEMICALS KNOWN TO CAUSE SERIOUS FATAL INJURY OR ILLNESS, SUCH AS RESPIRATORY DISEASE, CANCER, BIRTH DEFECTS OR OTHER REPRODUCTIVE HARM. IF YOU ARE UNFAMILIAR WITH THE RISKS ASSOCIATED WITH THE PARTICULAR MATERIAL BEING CUT, REVIEW THE MATERIAL SAFETY DATA SHEET AND/OR CONSULT YOU EMPLOYER, THE MATERIAL MANUFACTURER/SUPPLIER, GOVERNMENTAL AGENCIES SUCH AS OSHA AND NIOSH AND OTHER AUTHORITIES ON HAZARDOUS MATERIALS. CALIFORNIA AND SOME OTHER AUTHORITIES, FOR INSTANCE, HAVE PUBLISHED LISTS OF SUBSTANCES KNOWN TO CAUSE CANCER, REPRODUCTIVE TOXICITY, OR OTHER HARMFUL EFFECTS. CONTROL DUST, MIST AND FUMES AT THE SOURCE WHERE POSSIBLE. IN THIS REGARD USE GOOD WORK PRACTICES AND FOLLOW THE RECOMMENDATIONS OF THE MANUFACTURER/SUPPLIER, OSHA/NIOSH, AND OCCUPATIONAL AND TRADE ASSOCIATIONS. WHEN THE HAZARDS FROM INHALATION OF DUST, MISTS AND FUMES CANNOT BE ELIMINATED, THE OPERATOR AND ANY BYSTANDERS SHOULD ALWAYS WEAR A RESPIRATOR APPROVED BY OSHA/MSHA FOR THE MATERIAL BEING CUT.

Safety

ELECTRICAL PRACTICES



WARNING: ELECTRICAL CORDS CAN BE HAZARDOUS. MISUSE CAN RESULT IN FIRE OR DEATH BY ELECTRICAL SHOCK. READ CAREFULLY AND FOLLOW ALL DIRECTIONS.



CAUTION: ALWAYS FOLLOW APPLICABLE ELECTRICAL CODES, STANDARDS AND/OR REGULATIONS. CONSULT YOUR LOCAL ELECTRICAL AUTHORITY OR A LICENSED ELECTRICIAN BEFORE ATTEMPTING TO MODIFY AN ELECTRICAL INSTALLATION. ENSURE THAT CIRCUIT AND GROUND FAULT PROTECTION DEVICES AND ALL OTHER ELECTRICAL SAFETY EQUIPMENT ARE FUNCTIONING PROPERLY.

Extension Cord Requirements

- Ensure the cord type is suitable for the application and location. If you are unsure about your cord type, consult a qualified electrical professional or electrician.
- Ground your equipment. The equipment must be plugged into an appropriate outlet, one which is properly installed and grounded in accordance with all codes and ordinances. Do NOT modify the plug provided with the equipment. Never remove the grounding prong from the plug.
- Do not remove, bend or modify any metal prongs or pins of the plug. Modifications to power cords and/or plugs may result injury and/or equipment damage.
- FULLY INSERT plug into outlet.
- Do not use excessive force to make connections.
- Never unplug by pulling the cord from the outlet. Pull plug rather than cord to reduce the risk of damage.
- Regularly examine your extension cord and ensure it is in good electrical condition. Never use a damaged cord—either replace it or have it repaired by a qualified person.
- Protect your extension cords from sharp objects, excessive heat and damp or wet areas. Keep the cord away from oil, cutting edges and moving parts.
- Do not drive, drag or place objects over cord.
- Avoid overheating. Uncoil cord and do not cover it with any material.
- Avoid accidental starting. Be sure equipment is turned off before plugging in. Do not use equipment if the power switch does not turn the equipment on and off.
- Make sure equipment is not running before disconnecting cord.
- Unplug equipment. When not in use and before changing accessories or performing maintenance, unplug the machine.

Extension Cord Selection

All cords should be sized appropriately to reduce the risk of damage, fire or reduced performance. Reference the table in this section for cord sizes.

ELECTRICAL PRACTICES—CONTINUED

How to Use This Table

1. Determine your supply voltage.
2. Determine the total length of your cord including all extension cords.
3. Determine the maximum amp draw for your machine.
4. Trace your voltage across the top of the table to the first length that is greater than or equal to your cord length.
5. Follow the column down to the first row that contains a maximum amp draw greater than or equal to yours.
6. This cell contains the minimum wire size for your application.

Example

Application: Max Amps = 11A, Length = 40ft, Voltage = 120V

Solution: 40ft is between the 25ft and 50ft columns, so the larger of the two columns is chosen. Likewise, 11A is between the 10A and 12A rows, so the larger of the two rows is chosen. 14 AWG (2.5mm²) is the minimum wire size for this example.

Single Phase Equipment				
Max Length	120V Supply	25ft (7.5m)	50ft (15m)	75ft (22.5m)
	230V Supply	50ft (15m)	100ft (30m)	150ft (45m)
Max Amps		Minimum Wire Size		
8	16 AWG (1.5mm ²)	16 AWG (1.5mm ²)	16 AWG (1.5mm ²)	16 AWG (1.5mm ²)
10	16 AWG (1.5mm ²)	16 AWG (1.5mm ²)	16 AWG (1.5mm ²)	16 AWG (1.5mm ²)
12	14 AWG (2.5mm ²)	14 AWG (2.5mm ²)	14 AWG (2.5mm ²)	14 AWG (2.5mm ²)
14	14 AWG (2.5mm ²)	14 AWG (2.5mm ²)	14 AWG (2.5mm ²)	14 AWG (2.5mm ²)

Extension Cord Sizes

Single Phase Equipment							
Max Length	120V Supply	25ft (7.5m)	50ft (15m)	75ft (25m)	100ft (30m)	150ft (45m)	200ft (60m)
	230V Supply	50ft (15m)	100ft (30m)	150ft (45m)	200ft (60m)	300ft (90m)	400ft (120m)
Max Amps		Minimum Wire Size					
8	16 AWG (1.5mm ²)	16 AWG (1.5mm ²)	16 AWG (1.5mm ²)	16 AWG (1.5mm ²)	16 AWG (1.5mm ²)	14 AWG (2.5mm ²)	14 AWG (2.5mm ²)
10	16 AWG (1.5mm ²)	16 AWG (1.5mm ²)	16 AWG (1.5mm ²)	16 AWG (1.5mm ²)	16 AWG (1.5mm ²)	14 AWG (2.5mm ²)	12 AWG (4mm ²)
12	14 AWG (2.5mm ²)	14 AWG (2.5mm ²)	14 AWG (2.5mm ²)	14 AWG (2.5mm ²)	14 AWG (2.5mm ²)	12 AWG (4mm ²)	12 AWG (4mm ²)
14	14 AWG (2.5mm ²)	14 AWG (2.5mm ²)	14 AWG (2.5mm ²)	14 AWG (2.5mm ²)	14 AWG (2.5mm ²)	12 AWG (4mm ²)	10 AWG (6mm ²)
16	14 AWG (2.5mm ²)	14 AWG (2.5mm ²)	14 AWG (2.5mm ²)	14 AWG (2.5mm ²)	14 AWG (2.5mm ²)	12 AWG (4mm ²)	10 AWG (6mm ²)
18	14 AWG (2.5mm ²)	14 AWG (2.5mm ²)	14 AWG (2.5mm ²)	12 AWG (4mm ²)	12 AWG (4mm ²)	12 AWG (4mm ²)	10 AWG (6mm ²)
20	12 AWG (4mm ²)	12 AWG (4mm ²)	12 AWG (4mm ²)	12 AWG (4mm ²)	12 AWG (4mm ²)	10 AWG (6mm ²)	10 AWG (6mm ²)
25	12 AWG (4mm ²)	12 AWG (4mm ²)	12 AWG (4mm ²)	12 AWG (4mm ²)	12 AWG (4mm ²)	10 AWG (6mm ²)	8 AWG (10mm ²)
30	10 AWG (6mm ²)	10 AWG (6mm ²)	10 AWG (6mm ²)	10 AWG (6mm ²)	10 AWG (6mm ²)	8 AWG (10mm ²)	8 AWG (10mm ²)

Note: The table is based on a <10% voltage loss, data from the U.S. National Electrical Code Tables 400.5(A) & 400.5(B) and typical resistances for copper wire.

Components and Assembly



FIG. 1

FIG. 2

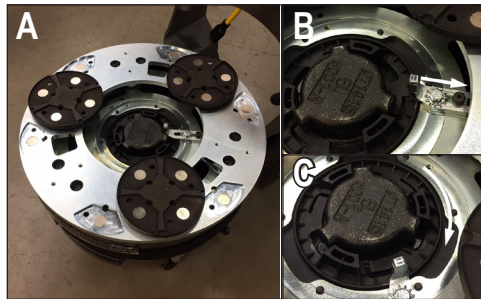

FIG. 3



FIG. 4

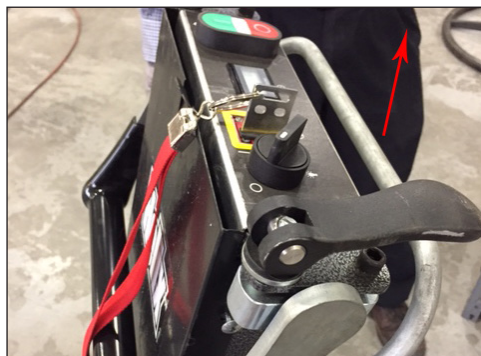

FIG. 5



FIG. 6

LOADING AND UNLOADING

- Always disconnect power, handle, and motor cords before transporting (Figure 1).
- Ensure blanks are installed in magnetic tooling pockets during transport.
- Disassemble machine for easy transport.

DISASSEMBLING AND ASSEMBLING MACHINE

The following steps are optional, and will separate the machine into five parts: the weights, base, tooling assembly, handle assembly, and dust skirt. To reassemble the machine, reverse these steps.

Removing the Weights

1. Remove the (4) 5.5 lb (2.5 kg) weights on top by removing the cotter pins that hold them in place. **Note:** *There is another 17 lb (7.7 kg) weight inside the base assembly that can be removed, but the tooling assembly must first be removed.*

Removing the Tooling Assembly

Disconnect machine from power, disconnect the handle cord from the motor cord (Figure 1), and remove the safety key and weights before completing the following steps:

1. If the dust skirt has not already been removed, ensure (4) skirt retainers are in position to keep the dust skirt in place (sticking outward). See Figure 2.
2. Flip base assembly over 180° until it rests on the two handles (Figure 3A).
3. Loosen the hex head cap bolt securing the locking tab and slide the locking tab back (Figure 3B). Rotate the tooling assembly clockwise to stop (Figure 3C).
4. Lift off tooling assembly; flip base back 180°.

Separating the Base Assembly

Disconnect machine from power and disconnect the handle cord from the motor cord (Figure 1) before completing the following steps:

1. Unlatch both bear claws while maintaining downward pressure on the lower handle; pull handle assembly away from the base assembly (Figure 4).

Removing the Dust Skirt

Remove weights and separate base assembly before completing the following steps:

1. Retract the (4) skirt retainers (Figure 2).
2. Slide the dust skirt up and off the base assembly.

To re-attach the dust skirt, there are two alignment tabs (one in the front, one in the back) on the base assembly. Line the notches in the skirt up with these tabs to attach properly. Re-position the skirt retainers to hold the dust skirt in place.

Folding the Handle Assembly

Remove weights and separate base assembly before completing the following steps:

1. Unlatch cam levers on handle, flip handle over the front of the electric box, and then re-engage the cam levers (Figure 5).
2. Pull handle-release lever out and rotate upper handle assembly down so that it folds into the lower handle assembly. It should re-engage with the lower notch when it has reached the correct position (Figure 6).

Components and Assembly

DUAL SPEED

There is a toggle switch on the motor for switching between speeds 1 and 2 (Figure 7).

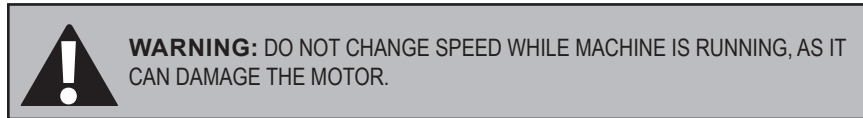

FIG. 7

VACUUM PORT

The machine has a vacuum port at the rear of the machine. Use a vacuum hose that snugly fits either on the outside (2") or the inside (1 3/4") of the port.

TOOLING SETUP

The Helix machine can perform either active grinding or passive planetary grinding depending on the tooling setup.

Prep and Removal Grinding

Use the grind and scape plate without the satellites for active grinding, scraping, removal and prep (Figure 10). This method is quicker and more aggressive than passive grinding. Metal bond diamonds, carbides, PCDs and directional tooling may be used.

1. Disconnect machine from power, disconnect the handle cord from the motor cord (Figure 1) and remove the safety key. Flip base assembly 180° until it rests on the two handles to expose the satellites (Figure 8).

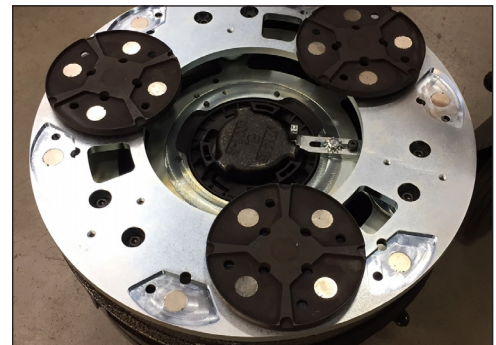
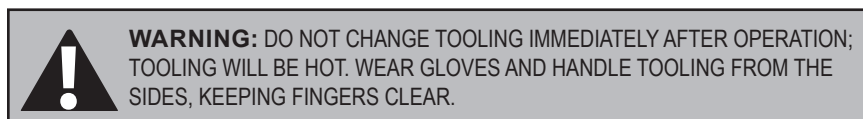

FIG. 8



FIG. 9

2. Remove each satellite by removing the cotter pin from the shaft and sliding the shaft from the bearing (see Tooling Assembly diagram in machine service manual for further instruction). Figure 9 shows satellites removed.
3. Clean foreign material from magnetic tooling pockets prior to tooling installation.
4. Insert the tooling segments into the magnetic pockets of grind and scrape plate (Figure 10). Be careful around pinch points, as the tooling will snap into place. For removal, insert screwdriver into gap and pop tooling out. For safety purposes, tooling segments should be attached to the plate using a single mounting screw (P/N 73097).

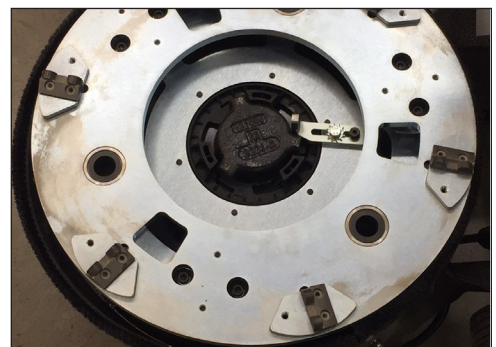
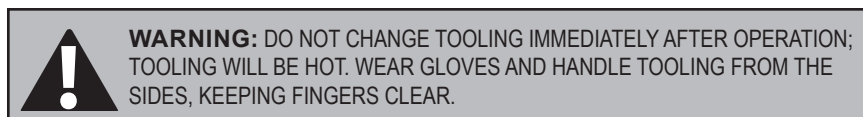

FIG. 10

Passive Planetary Grinding - Prep and Polish

Use the satellites for passive planetary grinding and polishing. This method can be slower and less aggressive than active grinding. Metal bond diamonds and polishing pads may be used. **Note:** *Directional tooling cannot be used with the satellites.*

1. Disconnect machine from power, disconnect the handle cord from the motor cord (Figure 1) and remove the safety key. Flip base assembly 180° until it rests on the two handles to expose the grind and scrape plate (Figure 9).



Components and Assembly

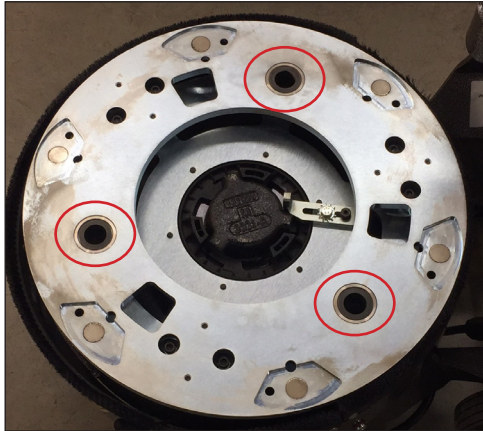

FIG. 11

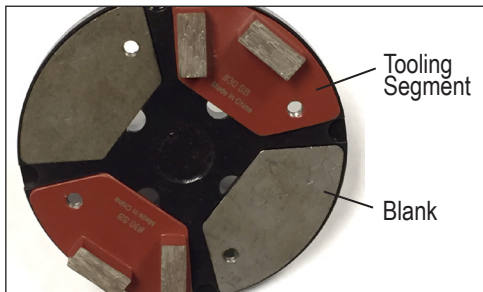

FIG. 12

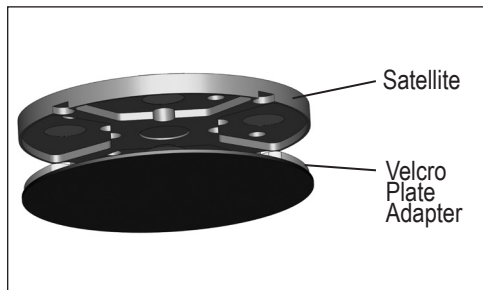

FIG. 13

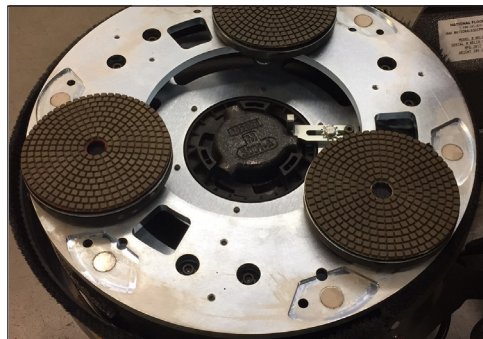

FIG. 14

- Using a rag, clean foreign material from the satellite bearing bores (Figure 11) and satellite shafts prior to installation. **Note:** Do not lubricate the bearing bores or shafts. The bearings are self-lubricating and do not require lubrication. Adding lubrication will attract foreign material which could cause improper rotation of the satellites.

CAUTION: FAILURE TO PROPERLY CLEAN THE SATELLITE BEARING BORES AND/OR SATELLITE SHAFTS MAY RESULT IN IMPROPER ROTATION OR STICKING OF THE SATELLITES.

- Install each satellite by sliding the shaft through the bearing and inserting the cotter pin through the shaft (see Tooling Assembly diagram in machine service manual for further instruction). Figure 14 shows satellites installed.
- Clean foreign material from magnetic tooling pockets prior to tooling installation.
- Place the tooling into the magnetic pockets of satellite. Be careful around pinch points, as the tooling will snap into place.

Tooling Segments

Insert tooling segments into two (opposite sides) or four pockets (Figure 12). **Note:** Use blanks (P/N 9500) in unused pockets. For removal, insert screwdriver into gap and pop tooling out. For safety purposes, each tooling segment should be attached to the satellite using a single mounting screw (P/N 73097).

Velcro Plate Adapter and Polishing Pads

The Velcro plate adaptor (P/N 9245) attaches magnetically to the satellite and snaps into place (Figure 13). Brazed diamond and polishing pads are attached to the Velcro plate adaptors (Figure 14).

Components and Assembly

EDGE GRINDING

Opening the edge grinding guard allows the machine to operate within 1/8" of the wall. The dust skirt may be oriented with the guard on the left or right side of the machine to allow for edge grinding on either side. **Note:** Before performing the following steps, disconnect machine from power and remove the safety key.

Opening the Edge Grinding Guard

If the edge grinding guard is already on the desired side, open the guard as follows:

1. Unlatch the guard.
2. Rotate the guard 180°.
3. Resecure the guard with the latch (Figure 15).

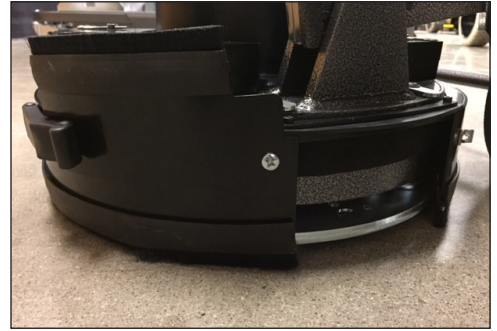

FIG. 15

Repositioning the Dust Skirt

If the guard is on the wrong side, the dust skirt must be repositioned as follows:

1. Disconnect the handle cord from the motor cord.
2. Detach the handle assembly from the base.
3. Retract skirt retainers.
4. Lift up the dust skirt (Figure 16).
5. Rotate the dust skirt 180° until the notches in the skirt line up with the tabs on the front and back of the base.
6. Lower the dust skirt into place.
7. Reposition the skirt retainers (sticking outward) to secure the dust skirt.
8. Open the guard as described above.
9. Reattach the handle assembly to the base.
10. Reconnect the handle cord to the motor cord.



FIG. 16

Operation

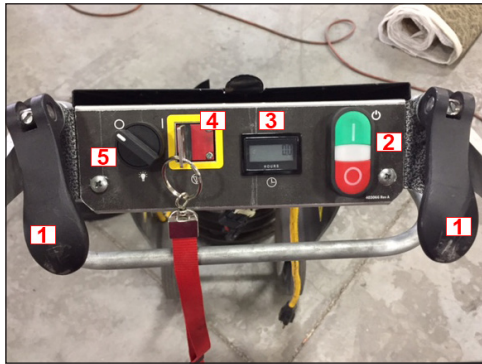

FIG. 16

PRE-OPERATION SAFETY CHECKS

- Ensure dust collector and hose are properly connected.
- Ensure dust skirt is attached.
- Ensure edge grinding guard is in place.
- Ensure all morflex coupler assemblies and magnetic tooling plates are securely fastened.



WARNING: MAKE SURE YOU ARE USING THE PROPER STYLE OF DUST COLLECTOR FOR WHAT YOU ARE GRINDING, SCRAPING, OR SANDING. FAILURE TO DO SO COULD CAUSE EMISSIONS OF HAZARDOUS PARTICULATES OR EXPLOSION DUE TO FINE DUST (E.G. WOOD SANDING), WHICH IS FLAMMABLE. MAKE SURE THE SYSTEM YOU ARE USING COMPLIES WITH OR EXCEEDS OSHA RECOMMENDED STANDARD. MAKE SURE THE RUBBER DUST GUARD IS COVERING ALL THE WAY TO THE FLOOR SURFACE.

OPERATING CONTROLS

See Figure 16 for the controller components:

1. Cam levers
2. Motor on/off switch
3. Hour meter
4. Safety key switch
5. Light on/off switch

OPERATING PROCEDURE

1. Ensure key is not in the safety switch before plugging into power source.
2. Plug the motor cord into the handle cord plug (Figure 1).
3. Plug cord into proper size extension cord.
4. Plug extension cord into outlet.
5. Attach safety wrist wrap and insert safety key.



WARNING: DO NOT OPERATE MACHINE WITHOUT FIRST ATTACHING THE SAFETY WRIST WRAP.

6. Push down on handle to relieve pressure from the plate to the floor. If possible, start in a clean floor area.



WARNING: GRINDER MUST BE TOUCHING THE GROUND AT ALL TIMES DURING OPERATION. BASE OF GRINDER SHOULD NEVER BE LIFTED OFF THE GROUND SO THAT TOOLING IS EXPOSED WHEN THE MACHINE IS ON.

7. Press green “Start” button; machine will start. Once started, let plate contact floor with full pressure. **Note:** Failure to let plate contact floor with full pressure could cause damage to the motor.
8. Press red “Off” button or remove the safety key to stop the machine.

DOWN PRESSURE

When grinding, down pressure relates to two aspects: (1) the amount of weight on the machine, and (2) the surface area the weight is being distributed across.

- If tooling with a smaller segment is used, the amount of down pressure applied at the point of contact is increased.
- Larger segments of tooling will decrease the amount of down pressure.

Down pressure will directly affect production rates and of profile achieved. If more down pressure is desired, insert the tooling segments into two of the four magnetic pockets. Be sure to insert the tooling into the magnetic pockets directly across from one another.



FIG. 17

ADJUSTING THE CAM LEVERS/HANDLE

The cam levers are used to adjust the handle; it has both a coarse and fine adjustment. For coarse adjustment, lift and rotate the entire cam lever 360° (Figure 17), then push the lever back down. For fine adjustment, use a flathead screwdriver and turn the screw 90° at a time (Figure 18).



FIG. 18

ADJUSTING THE LIGHT

The light can be tilted up or down by hand for adjustment (Figure 19).



FIG. 19

THIS PAGE INTENTIONALLY LEFT BLANK

Troubleshooting Guide

Problem	Solution
Machine is hard to handle	Change to a less aggressive tooling.
	Remove weights.
	Change handle position to gain better leverage.
Debris is coming out from the bottom of the machine	Check dust skirt to make sure it is mounted and secured properly. The bottom edge of the skirt should be touching the floor.
	Remove vacuum hose and check to see if port is plugged.
	Ensure dust collector is working properly.
Blows fuses or circuit breakers	Ensure use of proper extension cord. See Safety section.
	Move to a different outlet on an independent circuit.
	Change to a less aggressive tooling.
	Remove weights.
Motor will not run	Ensure machine is connected to power.
	Check if light on motor is on; if so, change brushes.
	Ensure safety key is properly inserted.
	Ensure handle and motor cords are connected.
Noisy or excessive vibration	Change to a different tooling specific for the job.
	Ensure tooling is properly installed.
Light does not turn on	Ensure light is plugged in (just above where the light is located).
Satellites do not rotate freely	Clean satellite bearing bores and satellite shafts.

Note: For further assistance, contact NFE customer service.

Maintenance



FIG. 1



WARNING: BEFORE STARTING REPAIR OR MAINTENANCE WORK, ALWAYS TURN OFF THE MACHINE, WAIT FOR STANDSTILL OF ALL DEVICES, PULL OUT THE MAIN PLUGS AND REMOVE THE SAFETY KEY TO SECURE THE MACHINE AGAINST UNINTENDED STARTUP.

GENERAL MAINTENANCE

A well-maintained machine is a productive machine. If not properly maintained, it could be unsafe or break down. Schedule regular maintenance check-ups to ensure efficient performance and a long life. The following maintenance should be performed by an NFE service center or dealer:

- Mechanical inspection and cleaning (bearings, nuts, bolts, housing, labels, etc.).
- Replacing worn or damaged parts (switches, guards, etc.).
- Electrical inspection (switch, cord, plugs, etc.).
- Testing to assure proper mechanical and electrical operation.

Labels should also be replaced if worn or difficult to read. Contact NFE for replacement labels.

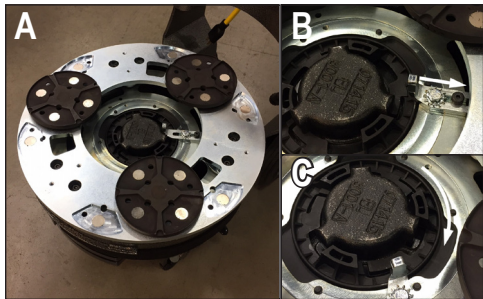

FIG. 2

REMOVING TOOLING ASSEMBLY

1. Disconnect machine from power; disconnect the handle cord from the motor cord (Figure 1); remove the safety key.
2. Remove the top weights by removing the cotter pins that hold them in place.
3. If the dust skirt has not already been removed, ensure the (4) skirt retainers are in position to keep the dust skirt in place (sticking outward).
4. Flip base assembly over 180° until it rests on the two handles (Figure 2A).
5. Loosen the hex head cap bolt securing the locking tab and slide the locking tab back (Figure 2B). Rotate the tooling assembly clockwise to stop (Figure 2C).
6. Lift off tooling assembly.
7. To reinstall the tooling assembly, reverse the above steps.

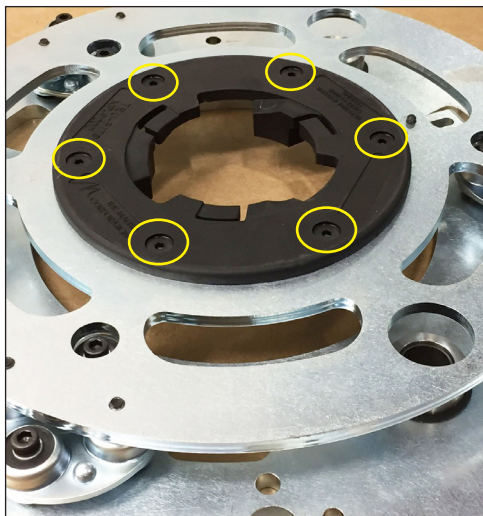

FIG. 3

REPLACING NYLON CLUTCH

1. Follow *Removing Tooling Assembly* procedure to gain access to the nylon clutch.
2. Remove the (6) screws (P/N 74620) using a 4mm Allen wrench (see Figure 3).
3. Discard the damaged clutch.
4. Orient the nylon clutch (P/N 403978) so that any one of the (3) clutch fingers (F) lines up with the locking tab (T). See Figure 4.
5. Tighten the (6) screws to 25 ft.lbs. using a 4mm Allen wrench.

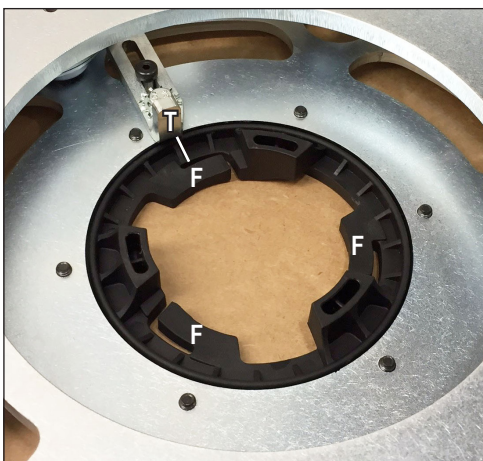

FIG. 4



CAUTION: MAKE SURE THE ORIENTATION OF THE NYLON CLUTCH IS CORRECT! OTHERWISE THE TOOLING ASSEMBLY WILL NOT BE PROPERLY SECURED IN THE BASE.

REPLACING SATELLITE BEARING ASSEMBLIES

1. Follow *Removing Tooling Assembly* procedure to gain access to the satellite bearing assemblies.
2. Remove the retaining ring using retaining ring pliers.
3. Remove the bearing assembly from the base plate (Figure 5).
4. Insert the new bearing assembly (P/N 404081) into the base plate.
5. Install the retaining ring using retaining ring pliers (Figures 5 and 6).

REPLACING MORFLEX COUPLERS

1. Follow *Removing Tooling Assembly* procedure to gain access to the Morflex couplers.
2. Remove the (4) retaining screws (two on each side of the coupler). See Figure 7.

Note: You may need to loosen the retaining screws of the other Morflex couplers to allow removal of the damaged coupler. See *Tooling Assembly diagram*.

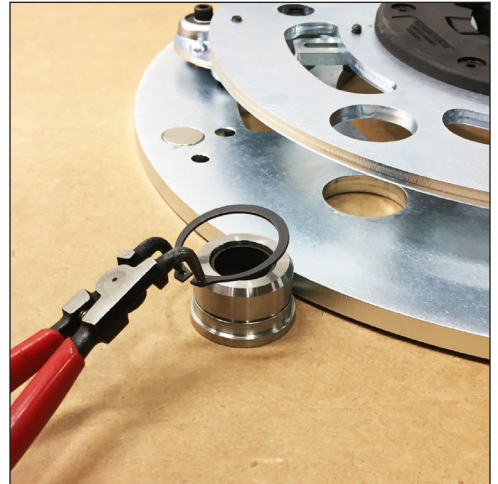

FIG. 5

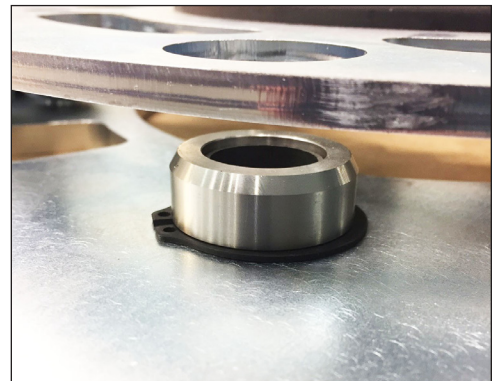

FIG. 6

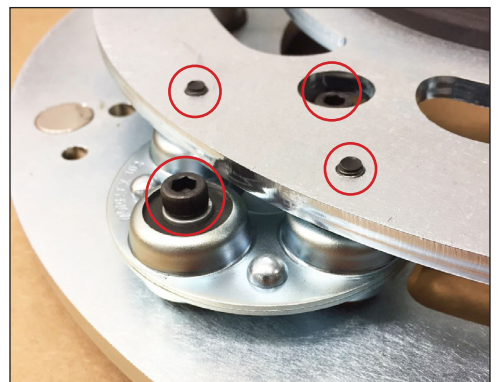

FIG. 7

Maintenance



FIG. 8

REPLACING MOTOR BRUSHES

Next to the dual speed toggle on the motor is a light (Figure 8). If the light is on, the brushes need to be replaced. To replace brushes, complete the following steps:

1. Disconnect machine from power; remove the safety key.
2. Remove (3) bolts on cover (Figure 9); remove cover. **Note:** Do not remove the commutator end bracket. Brushes can be installed through the openings in the bracket.
3. Remove (4) screws inside motor next to each brush (Figure 10).
4. Pull back spring and remove brush (Figure 11).
5. Replace brushes (wires should be on the top half of the brush). **Note:** Brush shunt should be out of the way of the spring or brush holder.

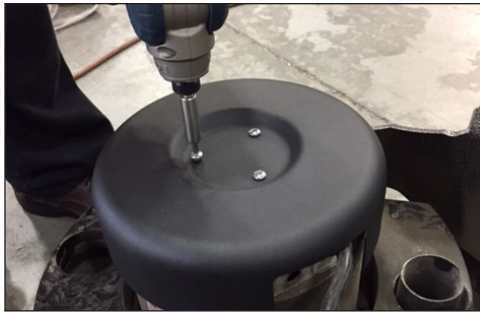
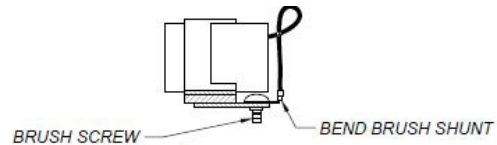

FIG. 9



6. Repeat for remaining brushes.

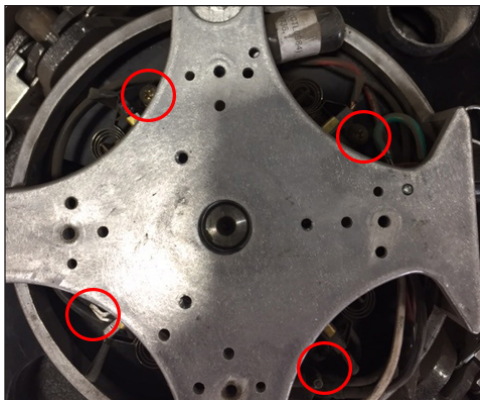

FIG. 10

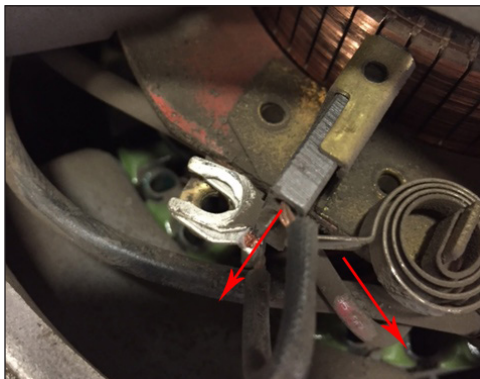

FIG. 11

LIGHT

If the light won't turn on, ensure that the plug is connected at the bottom of the control box (Figure 12).

ACCESSING ELECTRICAL COMPONENTS

1. Disconnect machine from power; remove the safety key.
2. Unplug light located under the cover (Figure 11).
3. Remove (4) bolts – 2 on the side, 2 on the top – on cover.
4. Remove cover.
5. Remove (4) screws – 2 on the top near controls, 2 on the bottom – from control panel.
6. Remove control panel to gain access to electrical components (Figure 13).



FIG. 12

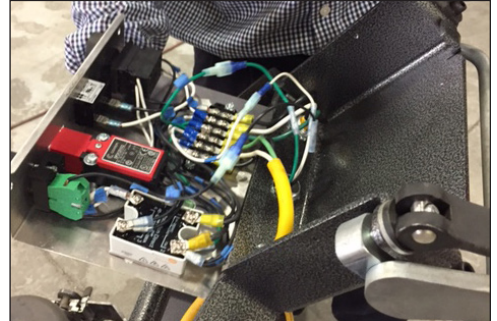
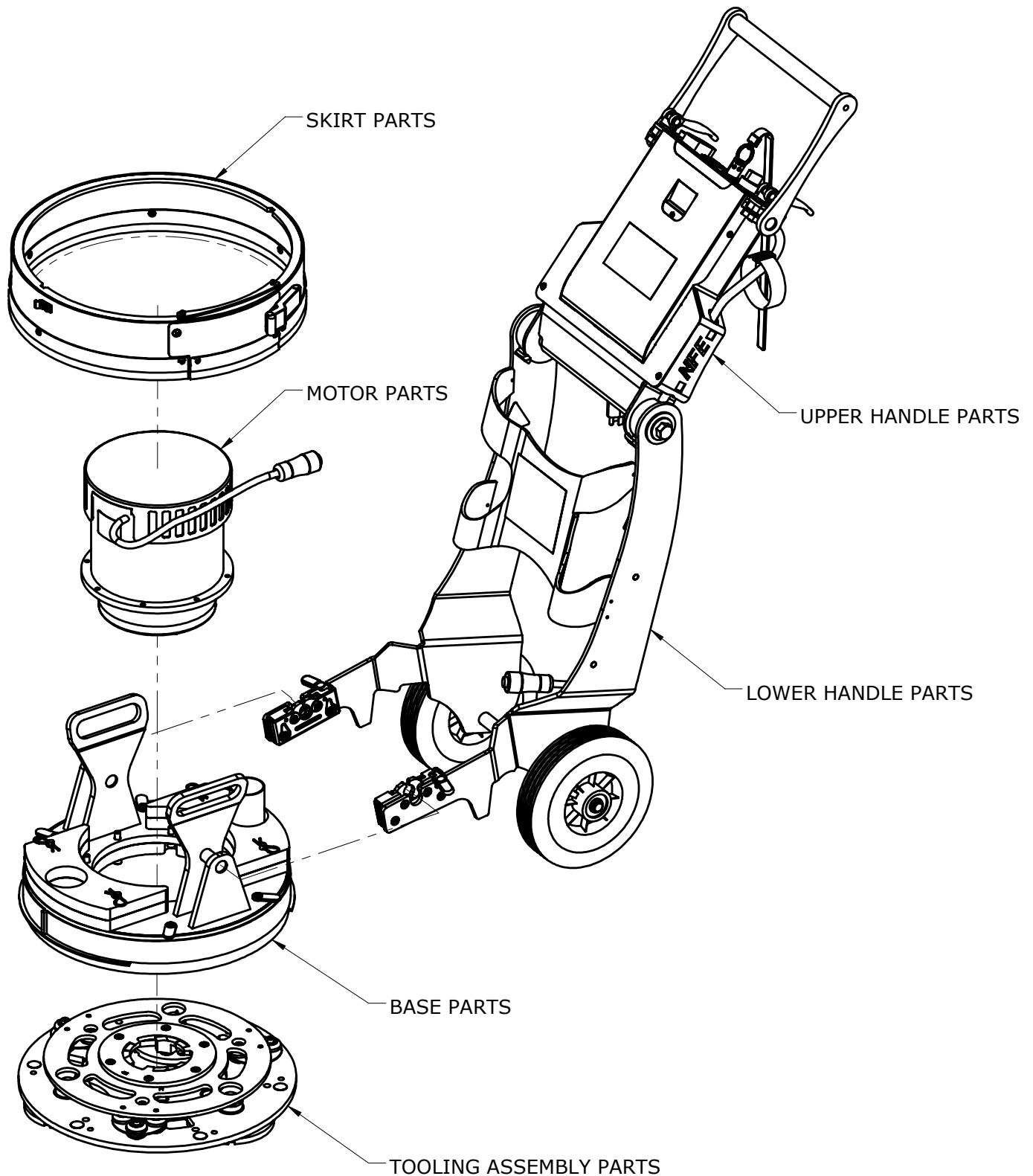

FIG. 13

Parts List and Diagrams

OVERALL MACHINE



Parts List and Diagrams

BASE ASSEMBLY

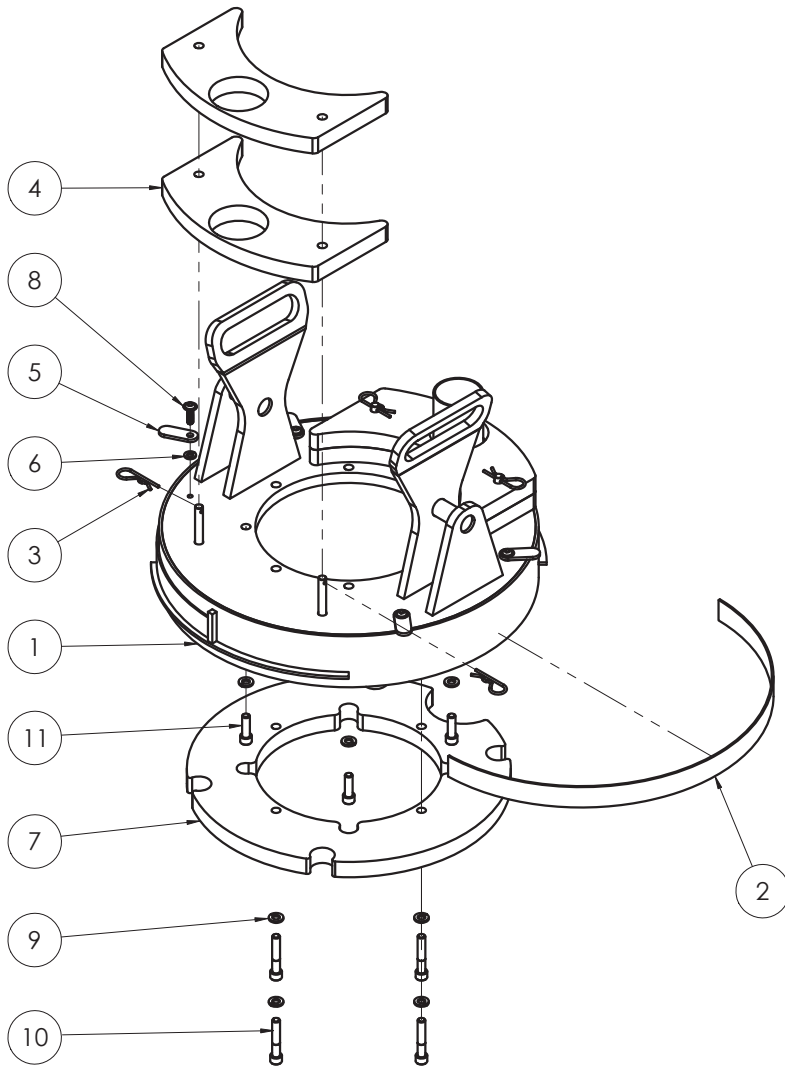

ITEM NO.	PART NUMBER	DESCRIPTION	QTY.
1	402798-SV	Shroud, Grinder, 15 inch, Imperial	1
2	402756	Seal, Felt, 1.5 x .078"	4'
3	402764	Pin, Weight, Hold Down	4
4	403004	Weight, Grinder, Imperial Gearbox	4
5	403165	Retainer, Skirt	4
6	403140	Washer, Flat, M6	4
7	403169	Weight, Ring, 12.5 x 3/4	1
8	403171	Screw, Flanged Socket Head Cap, M6-1.0 x 20mm	4
9	73303	Washer, Split Lock 5/16	8
10	73348	Screw, Socket Head Cap 5/16-18x1-3/4	4
11	73311	Screw, Socket Head Cap, 5/16-18 x 1	4

Parts List and Diagrams

402757 TOOLING ASSEMBLY

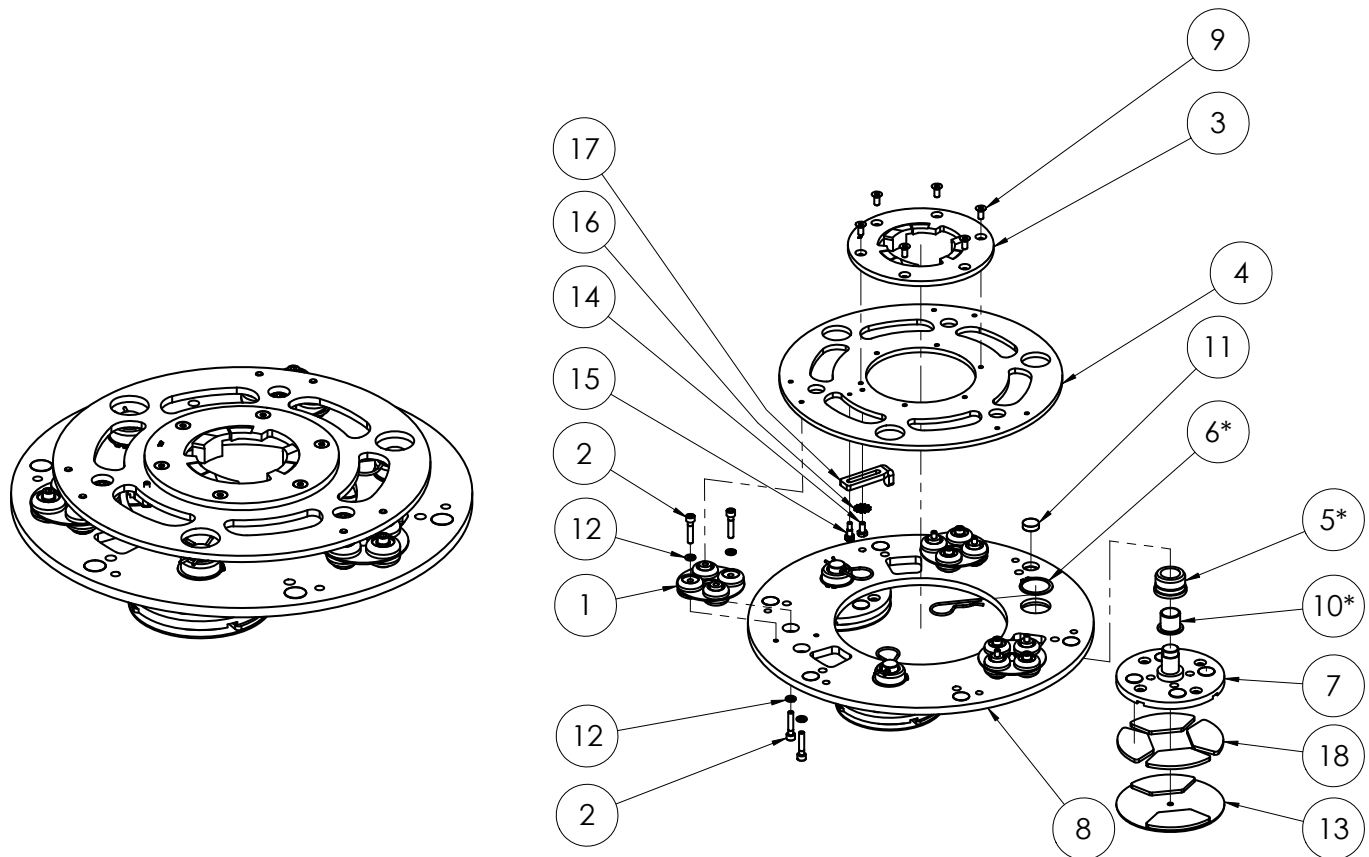

ITEM NO.	PART NUMBER	DESCRIPTION	QTY.
1	402781	Coupler, Morflex, 3.625"	3
2	402796	Screw, Socket Head Cap, M6-1.0 x 35mm	12
3	403978	Clutch, 5", Nylon	1
4	403979	Plate, Tooling, Clutch	1
5*	403994	Insert, Bearing, Flange, Tooling Plate	3
6*	404019	Clip, Retaining, Axial, 1.375	3
7	404021	Assembly, Satellite, Magnetic, 5" x 1.81"	3
8	404022	Ring, Tooling, Base	1
9	74620	Screw, Flat Head Socket Cap, M6-1.0 x 14	6
10*	404028	Bearing, Flange, Plain, 20 x 21.5mm	3
11	404084	Magnet, .75 Round, .250 Thick, N38SH	6
12	74619	Washer, Lock, M6	12
13	9245	Velcro Plate Adaptor	3
14	74630	Bolt, Hex Head Cap M6-12 8.8	1
15	404026	Bolt, Shoulder, 6mm x 8, M5-0.8	1
16	404027	Washer, Internal/External, 1/4"	1
17	403992	Retainer, Clutch, Slider	1
18	9500	Blank, Quick Change	12



*SOLD AS PART OF ASSEMBLED REPLACEMENT KIT# 404081

Parts List and Diagrams

403231 SKIRT ASSEMBLY

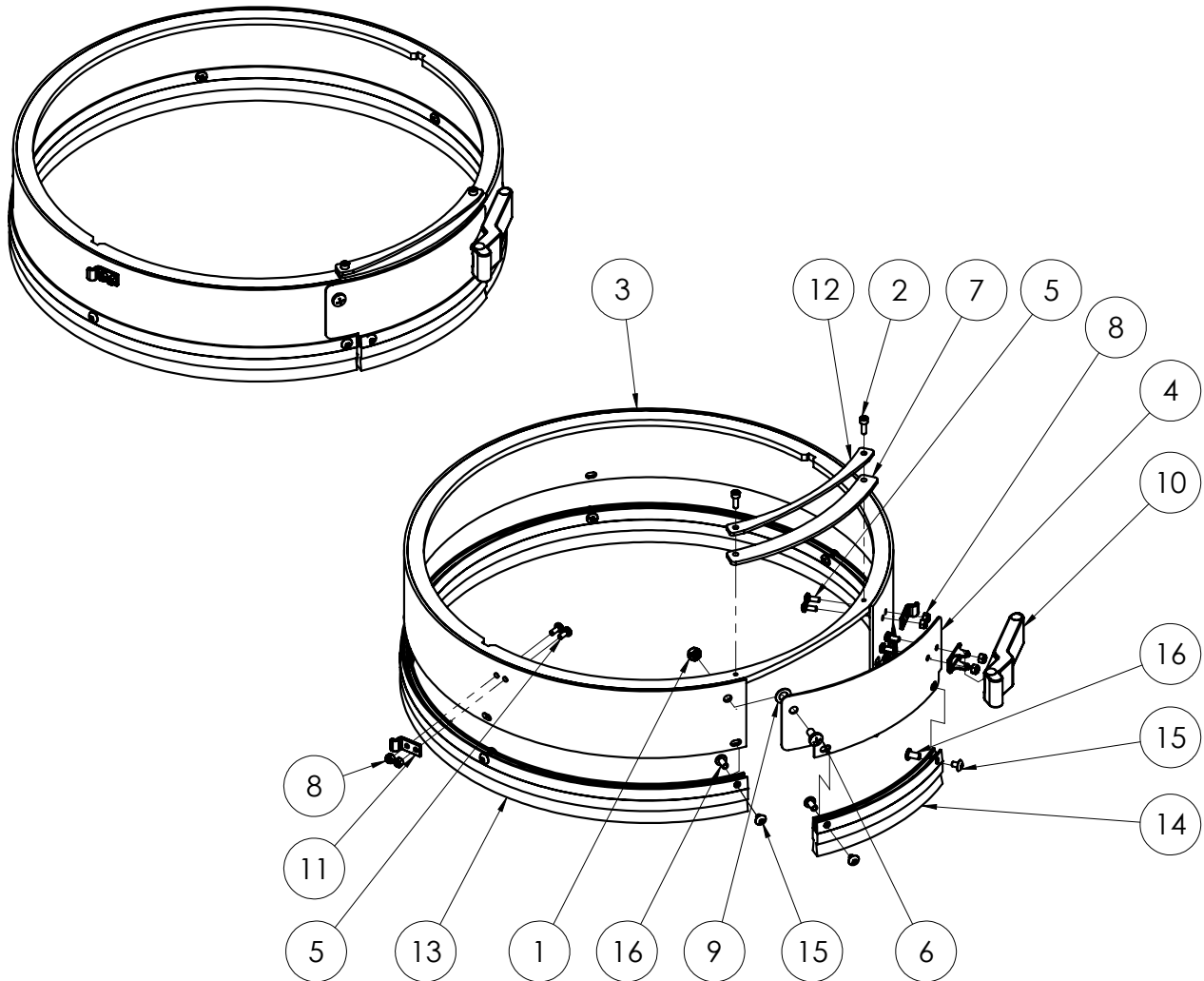

ITEM NO.	PART NUMBER	DESCRIPTION	QTY.
1	401516	Nut, M6-1.0 Nylock	1
2	401653	Screw, Socket Head Cap, M4-0.7 x 12	2
3	402705	Skirt, Floating, Edge Grinding, 16 inch	1
4	402755	Shield, Dust, Edge, Grinding	1
5	403075	Screw, Pan Head Machine, M4X0.7 - 10mm	6
6	403077	Screw, Pan Head Machine, M6X1.0 - 12mm	1
7	403168	Seal, Edge Grinding, Rubber	1
8	403170	Nut, M4-0.7, Nylock	6
9	403174	Washer, Flat, 1/4 x .031, Fiber	1
10	403180	Strap, Elastic	1
11	403186	Bracket, Elastic Strap	1
12	403193	Clamp, Rubber Edge Seal	1
13	403928	Brush, Strip, Skirt, 46"	1
14	403929	Brush, Strip, Skirt, 6"	1
15	403930	Screw, Oval Philips Head Machine Screw 8-32x1/4	8
16	403931	Screw, Truss Head Binding Post 13/64x3/8x8-32	8

Parts List and Diagrams

MOTOR

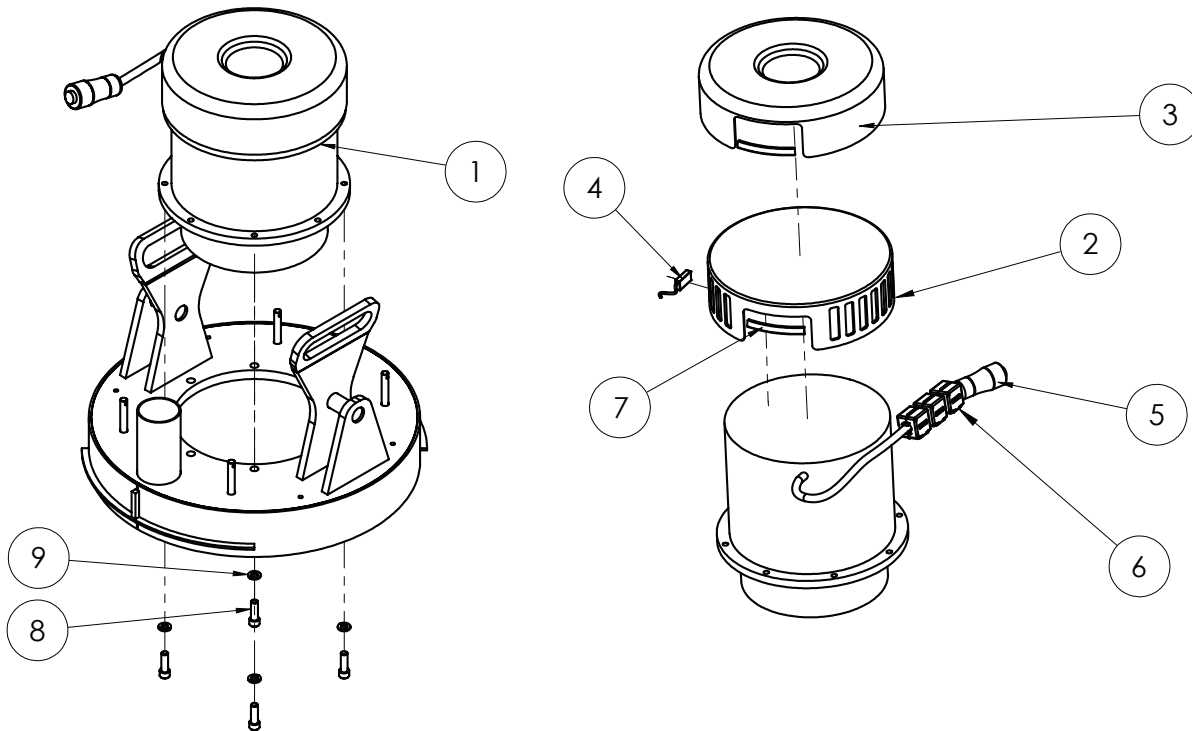

ITEM NO.	HELIX-10XXXX HELIX-12XXXX HELIX-23XXXX	HELIX-28XXXX	HELIX- 20XXXX	HELIX-11XXXX HELIX-13XXXX HELIX-15XXXX HELIX-26XXXX HELIX-27XXXX	DESCRIPTION	QTY.
1*	403152		403152		Assembly, Motor/Gearbox, 120 Volt	1
		403811		403902	Assembly, Motor/Gearbox, 100V, Japan	
					Assembly, Motor/Gearbox. 230 Volt	
2	403154	403154	403154	403154	Cover, Vented	1
3	403155	403155	403155	403155	Cover, Drip Proof	1
4	403319	403319	403319	403319	Brush, DC Motor	4
5	402801	402801	402801	402801	Plug, Male, 16A, 400V, 4C, Circular, Screw Terminal	1
6	N/A	403818	N/A	N/A	Ferrite, Solid, 50 Ohm, 1.047" OD x .504 ID	3
7	403382	403382	403382	403382	Trim, Edge, .23"W x .36"H	2.75"
8	73311	73311	73311	73311	Screw, Socket Head Cap, 5/16-18 x 1	4
9	73303	73303	73303	73303	Washer, Split Lock 5/16	4

*NOTE: Item 1 includes Items 2-7. Items 2-7 are also available separately.

Parts List and Diagrams

LOWER HANDLE ASSEMBLY

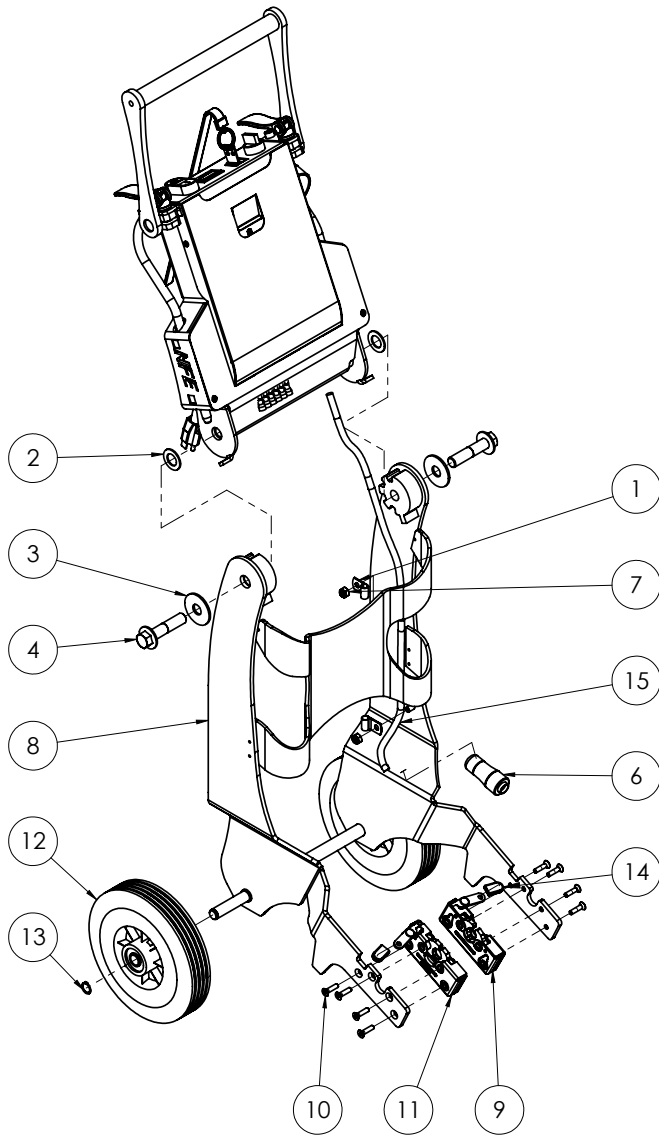

ITEM NO.	HELIX-10XXXX HELIX-12XXXX HELIX-23XXXX	HELIX-11XXXX HELIX-13XXXX HELIX-15XXXX HELIX-20XXXX HELIX-26XXXX HELIX-27XXXX HELIX-28XXXX	DESCRIPTION	QTY.
1	72873	72873	3/8 Cable Clamp	2
2	402721	402721	Washer, Nylon, Mil-spec, 3/4 inch ID x .03 inch thk	2
3	402725	402725	Washer, M16 x 50mm OD, Clear Zinc	2
4	402726	402726	Screw, Flange Head, M16x2.0 - 70mm	2
6	402802	402802	Receptacle, Female, 16A, 400V, 4C, Circular, Screw Terminal	1
7	401509	401509	Nut, M8-1.25 Nylock	2
8	402707-SV	402707-SV	Weldment, Lower Handle, Pivoting	1
9	402737	402737	Latch, Bear Jaw, Left	1
10	403076	403076	Screw, Flat Head Socket Head Cap, M6X1.0 - 25	8
11	402736	402736	Latch, Bear Jaw, Right	1
12	550-29	550-29	Wheel, 2-1/2 Center	2
13	402734	402734	Ring, Retaining, External, 5/8inch	2
14	402786	402786	Cap, Latch, Black Vinyl	2
15	72555		Cord, Power, SJEOW, 12/3, Yellow	3'
		72556	Cord, Power, H05VV-F, 2.5mm/3, Black	

Parts List and Diagrams

UPPER HANDLE ASSEMBLY

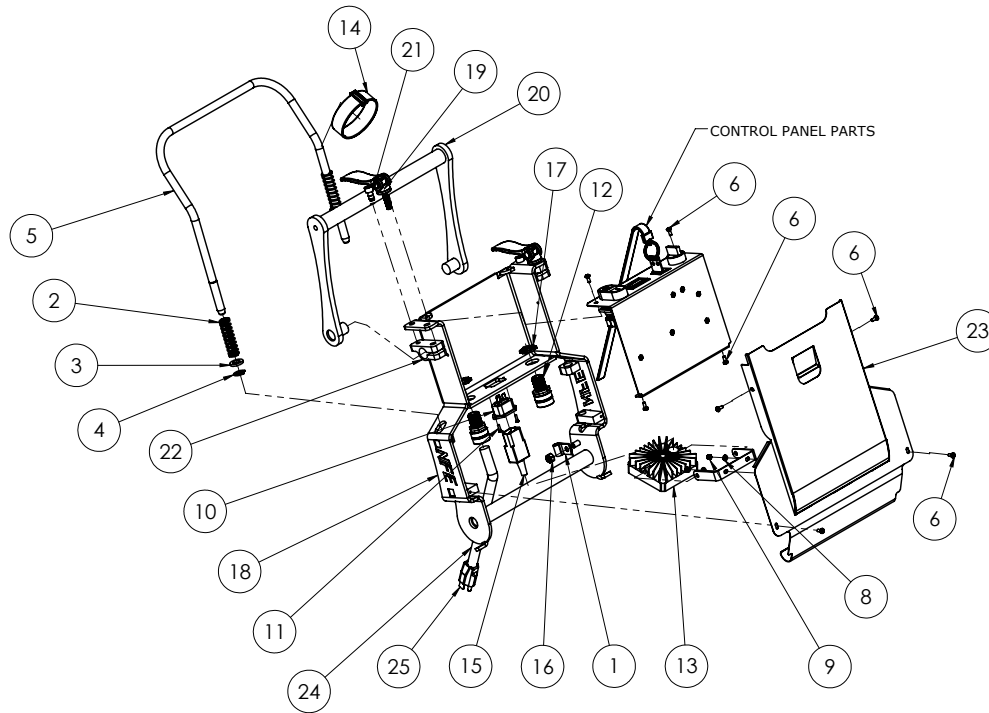

ITEM NO.	HELIX-10XXXX HELIX-12XXXX HELIX-23XXXX	HELIX-28XXXX	HELIX- 20XXXX	HELIX-11XXXX HELIX-13XXXX HELIX-15XXXX HELIX-26XXXX HELIX-27XXXX	DESCRIPTION	QTY.
1	72873	72873	72873	72873	3/8 Cable Clamp	1
2	402722	402722	402722	402722	Spring, .656"OD x 3"L x .062"W	2
3	402723	402723	402723	402723	Washer, Compression Retainer, 1/2" ID x 7/8" OD	2
4	80084	80084	80084	80084	E-Clip, 1/2" shaft	2
5	402724	402724	402724	402724	Handle, Pivot Control	1
6	403075	403075	403075	403075	Screw, Pan Head Machine, M4X0.7 - 10mm	8
8	401326	401326	401326	401326	WASHER, FLAT, M4	2
9	403170	403170	403170	403170	Nut, M4-0.7, Nylock	2
10	403176	403176	403176	403176	Receptacle, Panel Mount, IEC C-13, 250V, 15A	1
11	403187	403187	403187	403187	Screw, Flathead Machine, M3-0.5 x 12mm	2
12	72804	72804	72804	72804	Strain Relief, Straight, 1/2"	2
13	403157	403157	403157	403157	Light, LED, 12 Watt (Bracket included)	1
14	402797	402797	402797	402797	Cinch Strap, Velcro, 1" x 12"	1
15	403177	403177	403177	403177	Plug, IEC-14, 250V, 10A	1
16	401509	401509	401509	401509	Nut, M8-1.25 Nylock	1
17	73401	73401	73401	73401	Nut, Strain Relief, Steel, 1/2"	2
18	402716-SV	402716-SV	402716-SV	402716-SV	Weldment, Upper Handle, Pivoting	1
19	402729	402729	402729	402729	Lock, Cam, M8x1.25	2
20	402730	402730	402730	402730	Handle, Dipped	1
21	403384	403384	403384	403384	Screw, Socket Head Cap, M8x1.25 - 16mm, Adhesive Patch	2
22	403179	403179	403179	403179	Clamp, Handle bar, 3/4 ID	2

NOTE: 6X 403185 (TERMINAL, RING, 12-10GA, #6) ARE NOT SHOWN

ITEM NO.	HELIX-10XXXX HELIX-23XXXX	HELIX-12XXXX	HELIX-28XXXX	HELIX-20XXXX	HELIX-11XXXX HELIX-13XXXX HELIX-26XXXX	HELIX-15XXXX	HELIX-27XXXX	DESCRIPTION	QTY.
23	402727-BLK	402727-G	403804-BLK	402727-BLK	403834-BLK	403834-O	403834-BLK	Cover, Handle, Upper, Pivoting	1
24	6280-168	6280-168	72565	72565	72565	72565	402839	Cord, Power	N/A
25			403719	401486	401438	401438		Plug, Electrical	1

Parts List and Diagrams

HANDLE ASSEMBLY (INTERNATIONAL ONLY)

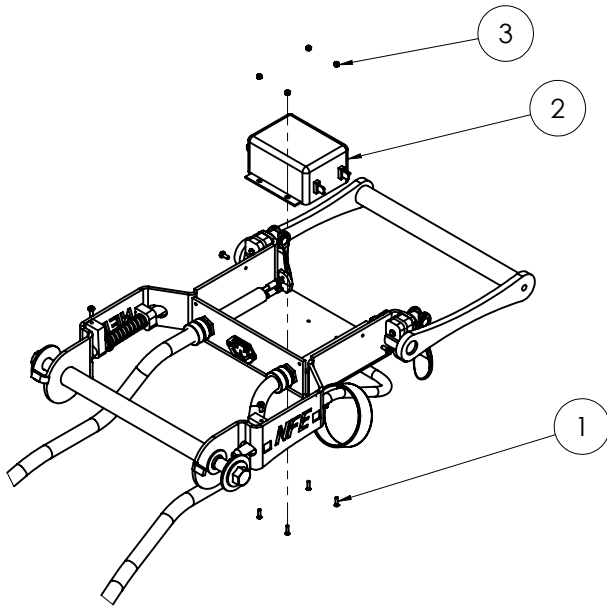

ITEM NO.	HELIX-11XXXX HELIX-13XXXX HELIX-15XXXX HELIX-26XXXX HELIX-27XXXX HELIX-28XXXX	DESCRIPTION	QTY.
1	403187	Screw, Flathead Machine, M3-0.5 x 12mm	6
2	403802	Filter, Electrical, 250V	1
3	403115	Nut, M3-0.5, Nylock	4
4*	72812	Terminal, QC, Female, Yellow Nylon, .250, 10-12AWG	5
5*	403150	Terminal, QC, Piggyback, Yellow Nylon, .250, 10-12AWG	1

NOTE: HELIX-10XXXX, HELIX-12XXXX, HELIX-20XXXX, HELIX-23XXXX WILL NOT NEED THESE PARTS

*NOT SHOWN

Parts List and Diagrams

CONTROL PANEL - 100/110/120V

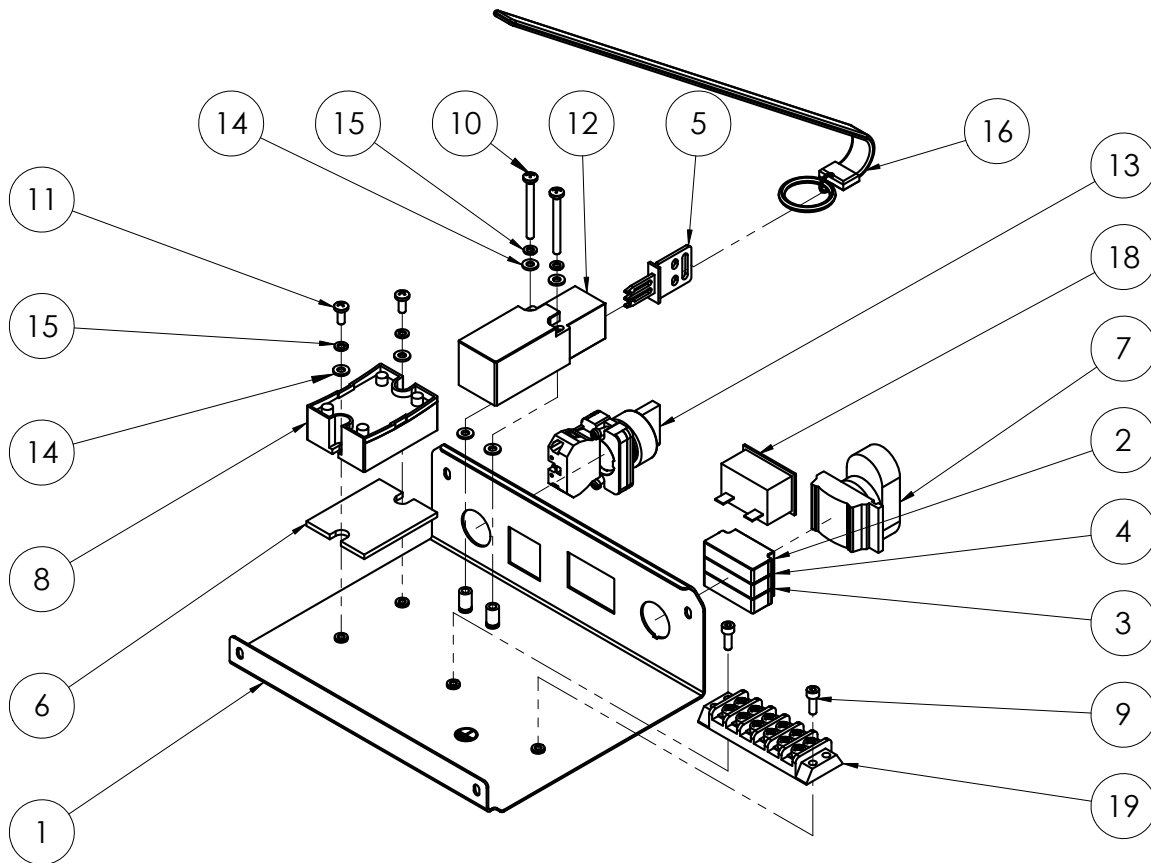

ITEM NO.	HELIX-10XXXX HELIX-12XXXX HELIX-20XXXX HELIX-23XXXX	HELIX-28XXXX	DESCRIPTION	QTY.
1	402768	403800	Cover, Electric Box, Pivoting Handle	1
2	403879	403879	Contact, NC, Pushbutton, BF	1
3	403880	403880	Contact, NO, Pushbutton, BF	1
4	403881	403881	Block, LED Lamp, Green, 110VAC, BF	1
5	402774	402774	Key, Safety Switch	1
6	402784	402784	Plate, Heat Sink, Relay	1
7	403877	403877	Pushbutton, On/Off, Light, BF	1
8	402772	402772	Relay, Solid State, 90-280VAC, 75A, SPST	1
9	401653	401653	SHCS, M4-0.7 x 12	2
10	402785	402785	Screw, PPH, M4-0.7 x 40mm, Zinc	2
11	403075	403075	Screw, Pan Head Machine, M4X0.7 - 10mm	2
12	402773	402773	Switch, Safety, 10A	1
13	403158	403158	Switch, Selector, Two position	1
14	401326	401326	Washer, Flat, M4	6
15	402787	402787	Washer, Lock, #8	4
16	403044	403044	Wrap, Wrist, Safety	1
18	403253	403253	Meter, Hour, Digital, 90-64VAC, 10-300VDC, 50/60Hz, Snap-on	1
19	403316	403316	Harness, Wire, M2000	1

NOTE: WIRES ARE NOT SHOWN FOR 403316

Parts List and Diagrams

CONTROL PANEL - 230V

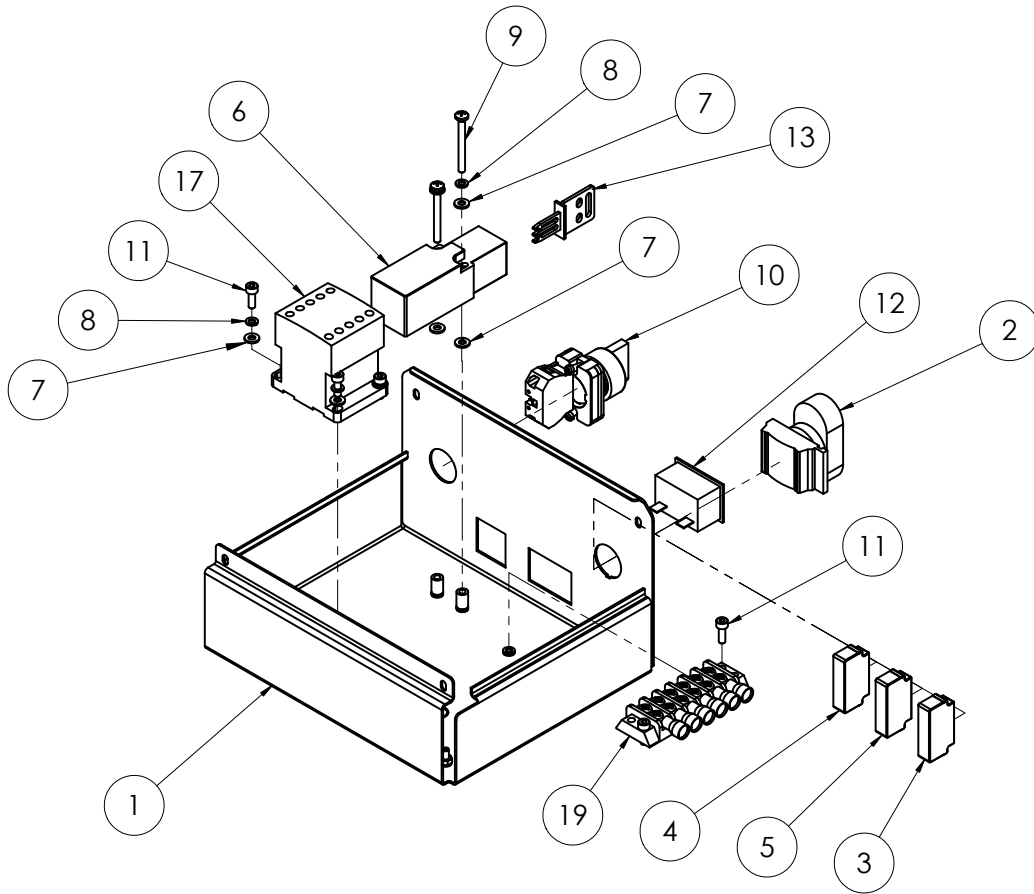

ITEM NO.	HELIX-11XXXX HELIX-13XXXX HELIX-15XXXX HELIX-26XXXX HELIX-27XXXX	DESCRIPTION	QTY.
1	403829	Cover, Electric Box, Pivoting Handle, 2.17" Flange	1
2	403877	Pushbutton, On/Off, Light, BF	1
3	403879	Contact, NC, Pushbutton, BF	1
4	403880	Contact, NO, Pushbutton, BF	1
5	403878	Block, LED Lamp, Green, 220VAC, BF	1
6	402773	Switch, Safety, 10A	1
7	401326	Washer, Flat, M4	8
8	402787	Washer, Lock, #8	7
9	402785	Screw, PPH, M4-0.7 x 40mm, Zinc	2
10	403158	Switch, Selector, Two position	1
11	401653	SHCS, M4-0.7 x 12	6
12	403253	Meter, Hour, Digital, 90-64VAC, 10-300VDC, 50/60Hz, Snap-on	1
13	402774	Key, Safety Switch	1
15	403044	Wrap, Wrist, Safety	1
16	403185	Terminal, Ring, 12-10ga, #6	6
17	403828	Contactor, 230V, 50/60Hz, 12A, 3 Pole	1
19	403873	Harness, Wire, Helix, 2.17" Flange	1

NOTE: WIRES ARE NOT SHOWN FOR 403873

Parts List and Diagrams

LABELS

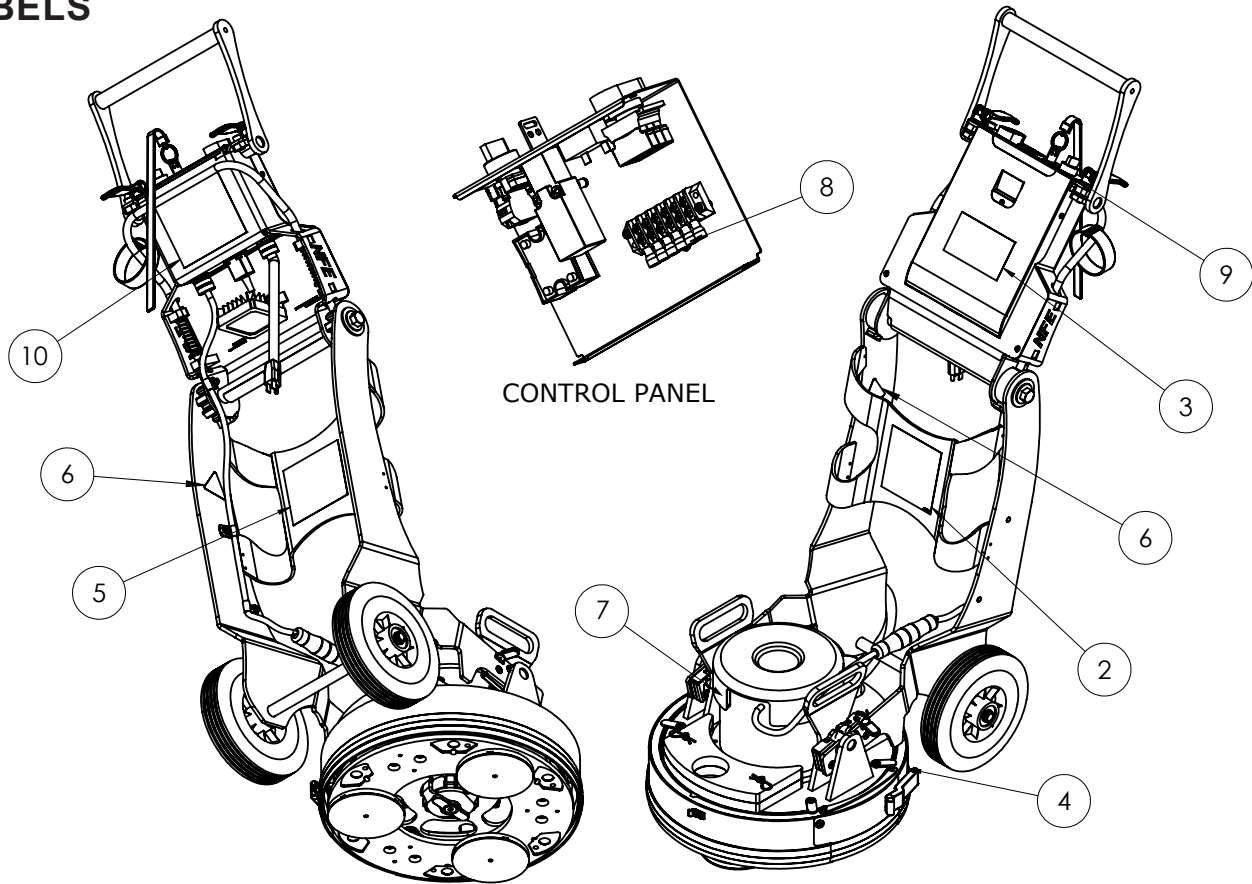

ITEM NO.	HELIX-XXXXXX	DESCRIPTION	QTY.
1*	403358-XX	Kit, Labels, Helix, [LANGUAGE]	1
2**	402463	Label, National Logo, 4.5 x 4.5	1
3**	403049	Label, Helix	1
4**	403060	Label, Entanglement Hazard	1
5**	403062	Label, Safety Guideline	1
6**	403065	Label, Pinch Point Hazard	2
7**	403649	Label, Motor Speed Change	1

*Kit includes Items 2-7. Suffix (-XX) denotes language: None=English; -FR=French; -NL=Dutch; -DE=German; -JA=Japanese.

**Item included in kit. Also available separately in English only.

ITEM NO.	HELIX-10XXXX HELIX-12XXXX HELIX-23XXXX	HELIX-20XXXX	HELIX-28XXXX	HELIX-11XXXX HELIX-13XXXX HELIX-15XXXX HELIX-26XXXX HELIX-27XXXX	DESCRIPTION	QTY.
8	403086	403086	403086	403086	Label, Ground	1
9	403066	403066			Label, Control Panel	1
			403831	403831	Label, Control Panel, International	
10	403061				Label, CE, Helix, 120V, 60Hz	1
		403904			Label, CE, Helix, 110V, 50Hz	
			403905-JA		Label, CE, Helix, 100V, 50Hz, Japanese	
				403903	Label, CE, Helix, 230V, 50Hz	

Parts List and Diagrams

WIRING DIAGRAM - 110/120V (HELIX-10XXXX, -12XXXX, -20XXXX, -23XXXX ONLY)

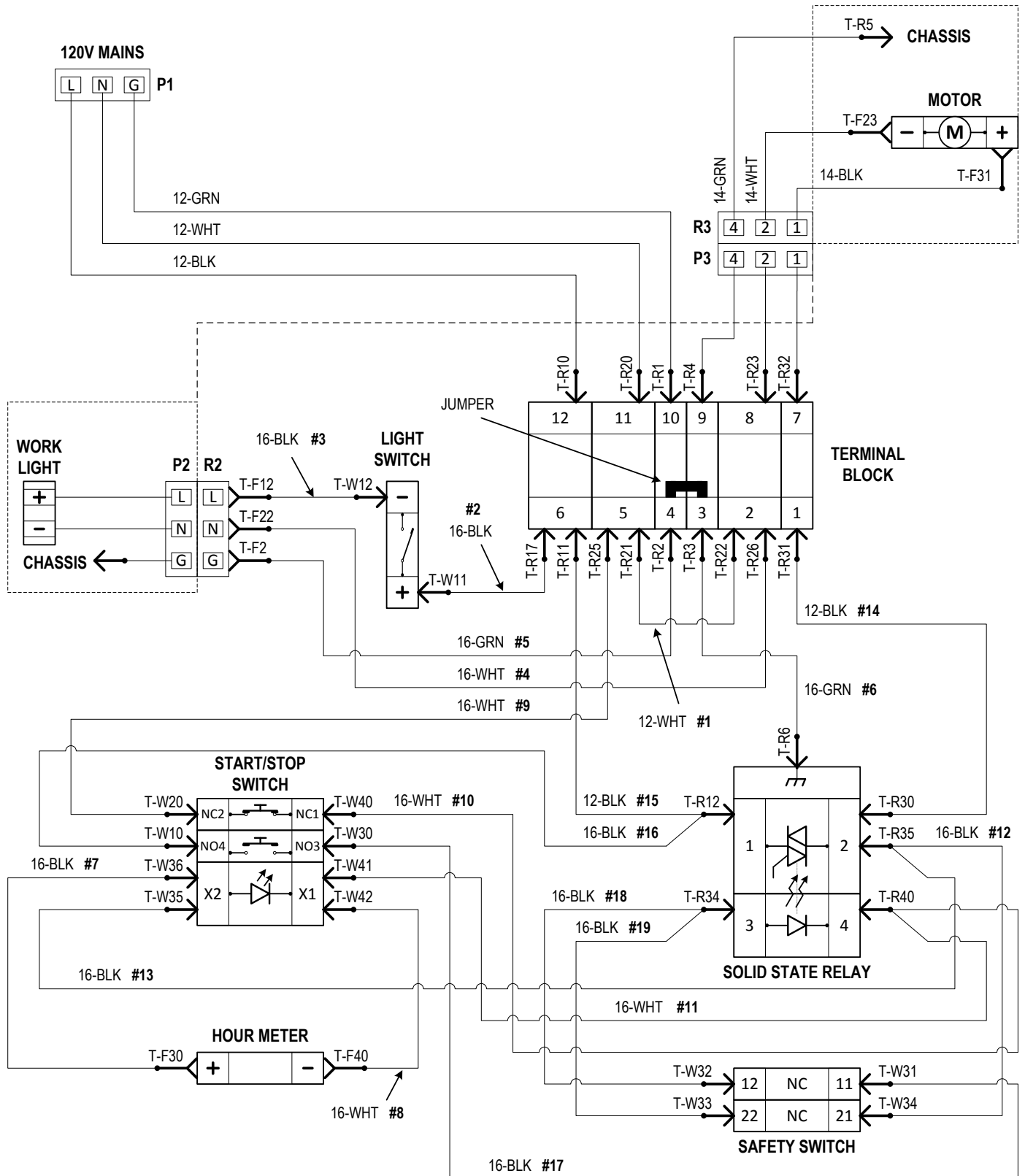

Parts List and Diagrams

WIRING DIAGRAM - 230V

(HELIX-11XXXX, -13XXXX, -15XXXX, -26XXXX, -27XXX ONLY)

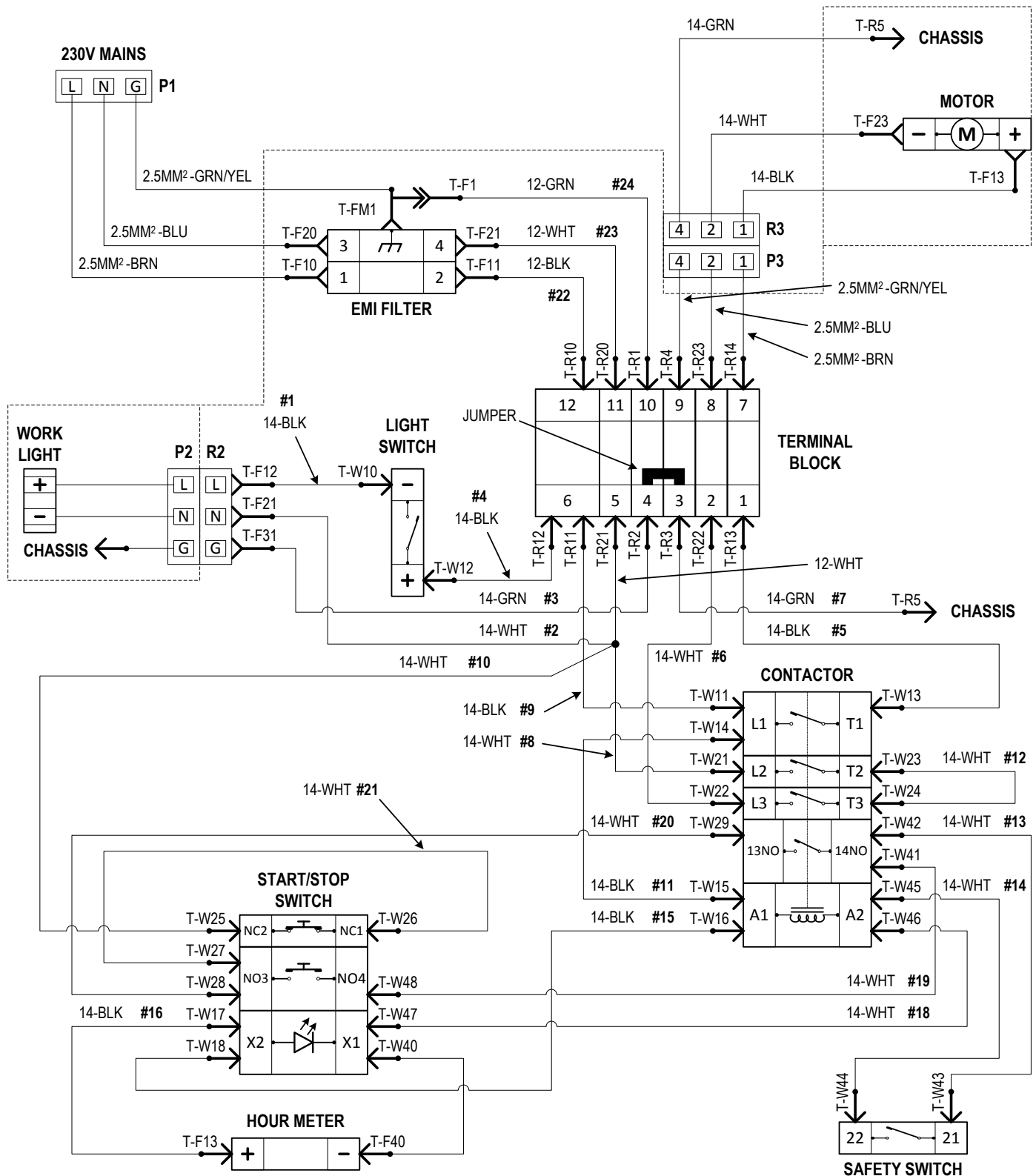

Parts List and Diagrams

WIRING DIAGRAM - 100V (HELIX-28XXXX ONLY)

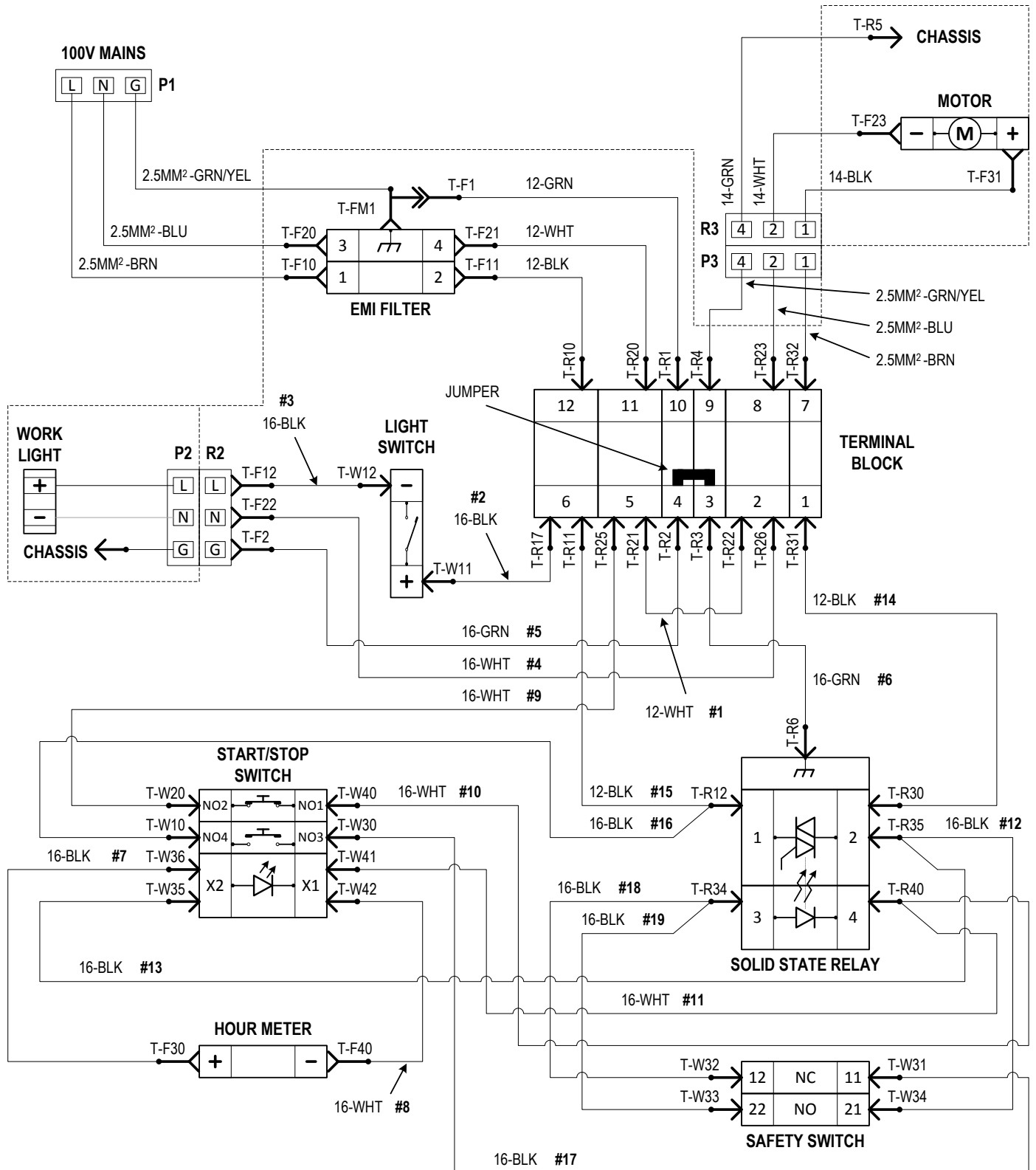



Made in America Since 1968

9250 Xylon Avenue N • Minneapolis, MN 55445 • U.S.A.
Toll-free 800-245-0267 • Phone 763-315-5300 • Fax 800-648-7124 • Fax 763-535-8255
Web Site: www.nationalequipmentdirect.com • E-Mail: info@nationalequipment.com